

SmartTether™ Operating Manual

Version 3.1



106 Pronghorn Trail
Bozeman, MT 59718
Tel: 406-994-9354 Fax: 406-994-9218
www.anasphere.com info@anasphere.com

Table of Contents

1	Introduction.....	4
2	Quickstart Tutorial	4
2.1	SmartTether System Product Information.....	4
2.1.1	System Components.....	5
2.1.2	Checklist of Items Included	8
2.2	Before Flight	9
2.2.1	What You Will Need	9
2.2.2	Software Installation	9
2.2.3	Flight Module Assembly.....	10
2.2.4	Power Supplies.....	12
	Flight Modules	12
	Ground Station	12
2.3	During Flight Operations	13
2.3.1	Operating Precautions.....	13
2.3.2	System Setup & Flight Instructions	13
2.3.3	Basic Startup	14
2.3.4	Compass Calibration.....	14
2.3.5	LED Indicators during Operation	15
2.3.6	Attaching Modules to the Line	15
2.3.7	Balancing	16
2.3.8	Markers	17
2.3.9	Flight Software Sequence	17
3	Technical Specifications	19
3.1	Ground Station	19
3.2	Flight Modules	19
3.3	Maintenance	20
4	Troubleshooting	21
4.1	Harmful Interference	21
4.2	Communications Reset.....	21
5	Technical Support	21
6	Additional Information	21
6.1	Serial Communications	21

6.1.1 Direct Serial Link..... 22

6.1.2 Radio Modem Link..... 22

6.2 Extra Channels 22

6.3 Notices..... 22

6.4 Liability 23

6.5 Warranty 23

List of Figures

Figure 1. Flight Module5

Figure 2. Outer Housing Components6

Figure 3. Inner Housing Components.....7

Figure 4. Line Attachment Assembly.....10

Figure 5. Tail Fin Assembly11

Figure 6. Battery Compartment12

Figure 7. Line Attachment Diagram16

*The SmartTether™ system appeals to a variety of users and therefore is equipped with several features that meet each of those different needs. To take advantage of SmartTether's measurement features, the typical user can find the necessary information needed to operate the system by reading through the **Quickstart Tutorial (p. 4)**. It may not be necessary to proceed beyond these sections. For the more complex user and more demanding application, the remainder of the manual can be used as a reference for that additional information. This manual is a great tool to get you started. It tells you what you need to get your equipment up and running and introduces its many features.*

We really appreciate our customers and hope they take joy in our products as much as we do. It is Anasphere's goal to provide cost-effective products and support services to meet your needs. We always enjoy hearing from the people who use our products. Your experience is an invaluable source of information that we can use to continuously improve what we manufacture. We encourage you to contact or visit us to discuss any issues that relate to our products or your application.

1 Introduction

The SmartTether™ system is a wireless tethersonde that uses one or several modules to take measurements of the surrounding atmosphere and records that data over a period of time. The measured data in that time period can be transferred simultaneously from all modules and transferred graphically onto the user's computer. The measurement capabilities that come standard with the system are temperature, pressure, relative humidity and wind speed/direction. The module also allows the user to customize their system, so if interested, please contact Anasphere at 406-994-9354 for more information.

NOTE: SmartTether™ modules are designed to hang from the tether of an airborne platform and can therefore present a hazard to personnel and equipment on the ground if they should fall for any reason (platform failure, tether failure, or line attachment failure). Appropriate precautions should be taken to protect personnel and equipment on the ground, including the use of personal protective equipment such as hard hats.

2 Quickstart Tutorial

The Anasphere SmartTether™ represents a revolutionary approach to gathering atmospheric profiles within the lower troposphere, using tethered blimps, balloons, or kites. It is an order of magnitude faster and less expensive as compared to traditional tethersonde systems and allows users to collect data simultaneously at multiple points along the tether. There is no limit on the number of modules that may be flown; the only limits are the lifting capacity of the platform and data rate.

The heart of the SmartTether™ is a series of wireless data modules which are attached to the tether. The data rate has been tested at 1 Hz for 6 modules. The data modules can send wireless data to a PC-based receiver on the ground. The PC can also send commands to an individual module or the entire network.

2.1 SmartTether System Product Information

System Features:

Data Modules - The heart of SmartTether™ is a series of wireless data modules which are attached to the tether. The data modules transmit their data via radio modem to the ground station receiver with a PC interface.

Measurements - SmartTether™ modules measure pressure, temperature, relative humidity, wind speed, and wind direction. The modules have extra analog and digital inputs to which other sensors can be interfaced.

Measurement Applications:

Real-time Wind Profiles - SmartTether™ was originally designed to meet the needs of researchers studying highly variable boundary layer winds. These winds can be extremely variable even over small vertical distances of 50 feet. A user can see the

measurement data being collected from many units at different fixed points in the sky and that information can be instantly viewed and recorded at the user's fingertips.

Flux Measurements - Flux measurements are another area in which SmartTether™ can be applied. One approach to gathering flux measurements is to make several vertically separated measurements of the species of interest (such as carbon dioxide) from the ground to the top of the boundary layer, and then use mathematical models to calculate the flux.

Typical Applications:

- Boundary Layer Wind Profiling
- Fire Weather
- Pollution Monitoring
- Emergency Response

2.1.1 System Components

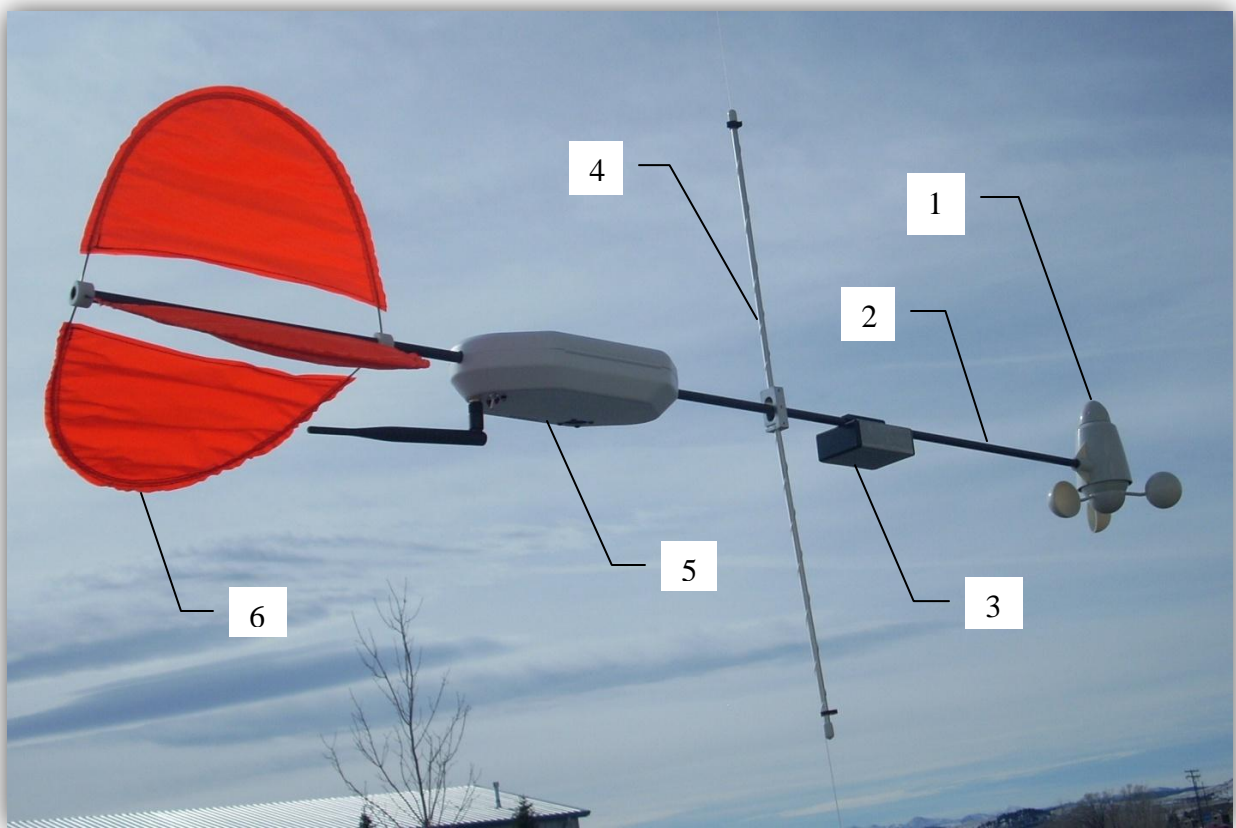

Figure 1. Flight Module

The SmartTether module shown in *Figure 1, Flight Module* on page 5 represents a fully assembled and balanced unit being operated in flight. The following indicates the different parts of the flight module:

- (1) Anemometer (Sonic or Cup Option Available)
- (2) Boom
- (3) Battery Compartment and Holder
- (4) Line Attachment Component
- (5) Housing with Electronics Board
- (6) Fins Assembly with Hubs

The electronic components can be found inside the white housing that holds the electronics board. Refer to *Figure 2, Outer Housing Components* for the location and description of the components found on the bottom exterior of the housing. Refer to *Figure 3, Inner Housing Components* on page 7 for the location and description on the components found inside the housing on the circuit board.

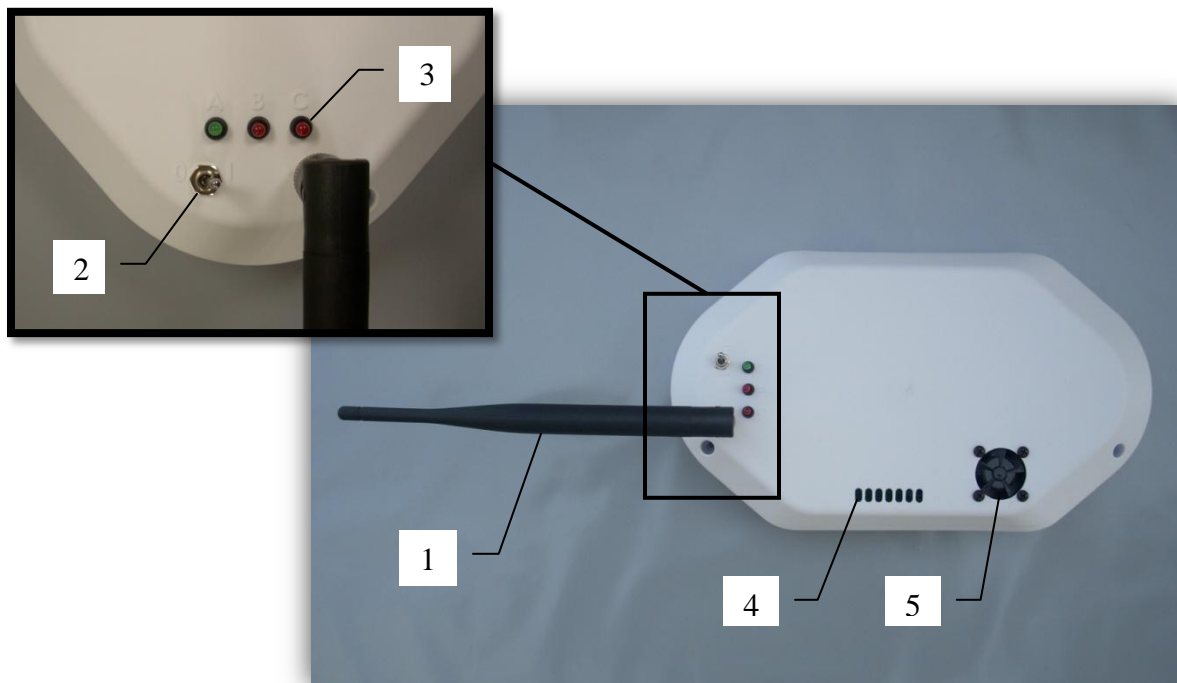

Figure 2. Outer Housing Components

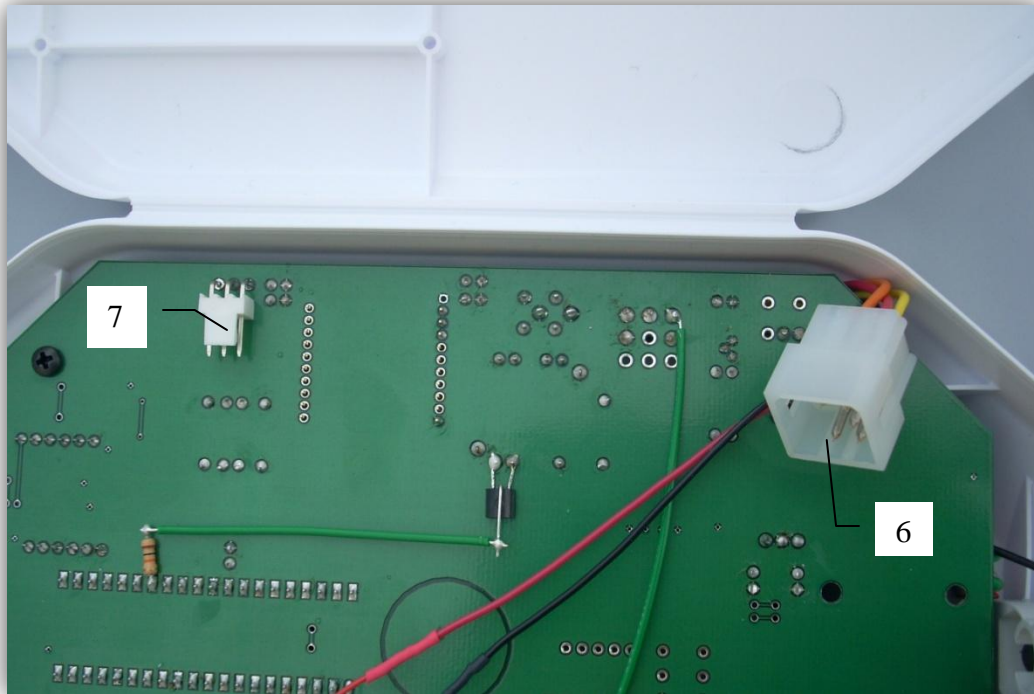

Figure 3. Inner Housing Components

This list corresponds to *Figure 2* and *Figure 3* on pages 6 and 7, which shows the main components that the user will work with on the housing and electronics board.

- (1) Antenna/Radio Modem Coaxial Jack Connection
- (2) Power Toggle Switch
- (3) LEDs (A,B, & C)
- (4) Airflow Vents
- (5) Airflow Fan
- (6) Power /Anemometer Connection
- (7) Firmware Updates and Calibration Port Connection (J2)

2.1.2 Checklist of Items Included

Flight Module

- ✓ 4' Carbon Fiber Boom w/ Anemometer Assembly
 - Cup or Sonic Anemometer (Depending on version purchased)
- ✓ White Polypropylene Housing w/ Circuit Boards
- ✓ Antenna
- ✓ Three Orange Fins
- ✓ Two Fin hubs
 - Four 4-40 x 3/16" Set Screws for Each Hub
- ✓ Line Attachment Component
 - Aluminum Rectangular Base
 - Two 12" Aluminum Tubes
 - Three 4-40 x 3/4" Set Screws
 - Two Plastic Snap-Grip Tube Clamps
 - Two Vinyl End Caps
- ✓ Battery Compartment
 - 8-AAA Battery Holder w/ Battery Snap
 - Three 4-40 x 1/8" Set Screws

Ground Station

- ✓ Aluminum Box Housing w/ Circuit Boards
- ✓ Antenna
- ✓ 16' Power Jack Cable

Software

- ✓ SmartTether™ Installation CD
 - Works with Windows XP® and Windows Vista®¹

1 Windows is a registered trademark of Microsoft Corporation in the United States and other countries.
2 Products Anasphere can provide for an additional cost. Please call for pricing information.

General

- ✓ 3 Pin Serial Adapter Cable for Flight Module
 - Used for Firmware Updates and Calibration Purposes
- ✓ 0.050 Hex Keys
- ✓ Extra Small Parts Bag

2.2 Before Flight

The following sections include important information needed before a flight is performed.

2.2.1 What You Will Need

The SmartTether™ system requires the user to supply some additional hardware to successfully use the system. This system is recommended for a tethered platform that has the capability to raise flight modules in the air such as balloons, blimps or kites. Anasphere is able to provide many of the recommended products that are compatible with the SmartTether™ system for an additional cost.

Additional Items Needed:

- ✓ Computer with an appropriate operating system and serial port
- ✓ 12VDC Power Source for Ground Station
- ✓ 8 AAA Batteries for Each Flight Module
- ✓ Balloon, Blimp or Kite ²
- ✓ Helium or other gas for lifting if necessary
- ✓ Winch and Tether Line System ²
- ✓ Sturdy Platform²
- ✓ 9 Pin RS-232 Cable ²
- ✓ Streamers ²

2.2.2 Software Installation

Included in the product shipment is a disc that contains the software required to run the SmartTether™ system. The program has been tested with Windows XP® and Windows Vista®. Load the disc into the applicable drive on your computer and follow the installation instructions as prompted.

If for whatever reason the software disc is lost or damaged, the software is available for download at www.anasphere.com. Also available at this site are software updates to ensure you have the latest version of the SmartTether™ system software.

- (1) Simply copy the file SmartTether.exe to any convenient location on your computer's hard drive. No special installation is required.

2.2.3 Flight Module Assembly

The SmartTether™ flight module is shipped partially assembled. The user needs to take the following steps to complete the assembly process. For a visual reference of a fully assembled flight module, please refer to *Figure 1. Flight Data Module* on page 5.

- (1) **Attach the Antenna.** Screw the antenna onto the radio modem coaxial jack located on the bottom of the white module housing. Refer to *Figure 2* on page 6 for location. Make sure the antenna is parallel with the boom and is pointed towards the back of the flight module.
- (2) **Line Attachment.** The aluminum rectangular base will be pre-installed onto the boom. The boom should have a degree of freedom to freely pivot up and down on the middle set screw. To finish the line attachment assembly, simply unscrew the top and bottom set screws enough so that both 12" aluminum tubes can be fully inserted into the top and bottom holes of the base. Twist the tubes so that the holes in the tubes line up with the set screws. Re-screw the set screws so that both ends are completely inside the base. All set screws should set inside both side walls so the tether line has nothing obstructing its path. Refer to *Figure 4. Line Attachment Assembly* as a reference. For a more permanent construction, using a thread locking substance on the set screws will keep the screws from loosening. Make sure that each tube has its own end cap and tube clamp.

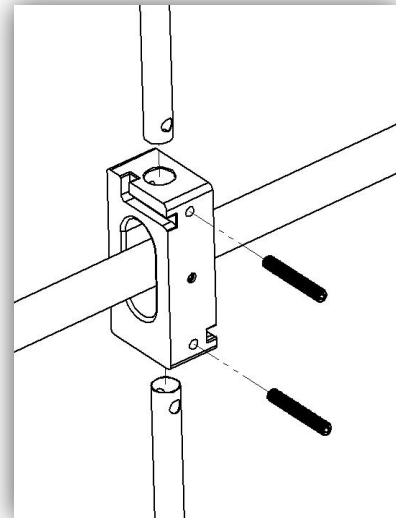

Figure 4. Line Attachment Assembly

- (3) **Fin Assembly.** To assemble the fins, the user will need the supplied three fins and two hubs. Each hub has four set screws, so begin by backing out the set screws enough to clear the holes. Now take the arms of the fins and make a nice big u-shaped curve and flatten out the orange plastic material so they are flat. Start with the first fin and place the arm of the fin into one of the insertion holes of the first hub. Remember to keep the center area of the hubs clear from the arms so they do not interfere with the boom sliding into place, which can happen if the arms are pushed too far into the holes. Using the included 0.050 hex key, gently tighten down the set screws to a point where the fin cannot be removed from the hub. Take care not to crush the arms of the fins with the set screws. Repeat this process for the remaining two fins and the remaining insertion holes of the first hub. Repeat the entire process again for the other side of the arms on all three fins into the insertion holes of the second hub. Refer to *Figure 5. Tail Fin Assembly* as a reference.

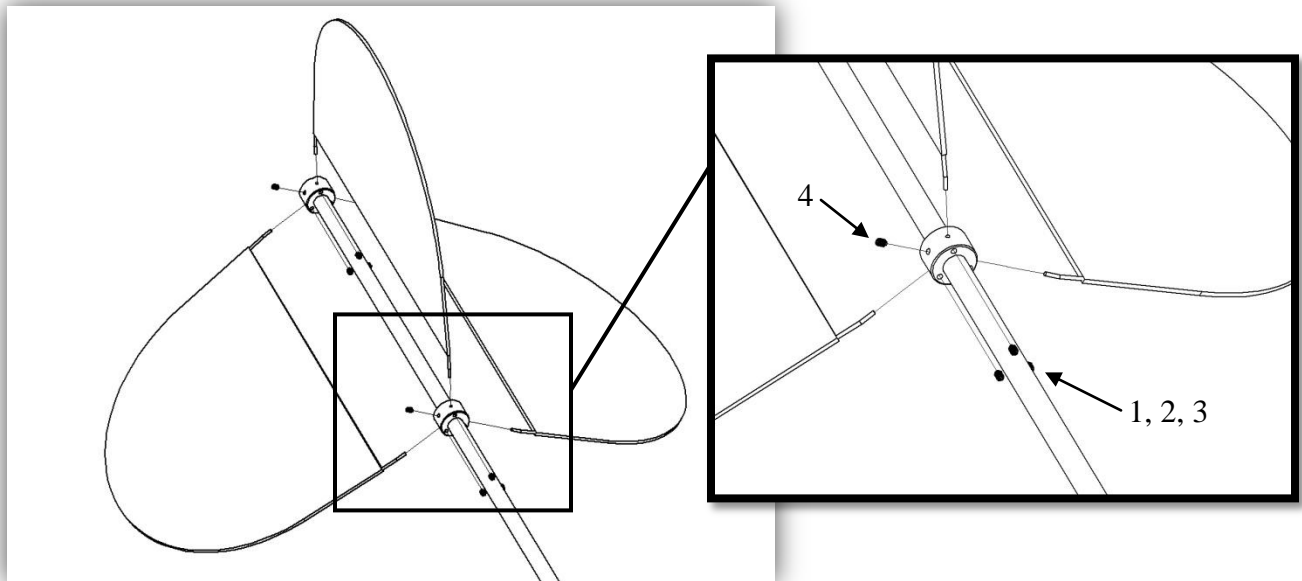

Figure 5. Tail Fin Assembly

- (4) Now slide the fin assembly onto the rear section of the carbon fiber shaft so that end of the tube is in line with the rear hub. Gently tighten down the remaining set screw on each hub to ensure the positioning of the hubs on the shaft. Be careful again not to over tighten. The included 0.050 hex key is the correct size for all the set screws. After the initial assembly of the fins and hubs, the completed assembly may be left on the boom and removed only if replacement of a fin or hub becomes necessary.
- (5) If the user purchased a cup anemometer version, then the cups will need to be installed onto the anemometer base. This is done by simply sliding the hole in the cup attachment onto the short metal shaft underneath the anemometer base and securing it with its set screw. Be sure the set screw is aligned with the flattened portion on the shaft. It is important to handle the cups gently during installation.

- (6) The battery holder is located inside the battery compartment. Slip out the battery holder and place eight AAA batteries inside the holder. Use care with the wires when sliding the battery holder back into position. Place the wires inside the notch on the battery holder before sliding it back inside. The battery snaps need to be connected. The snaps and extra wires can be fit into the end cap when closed. Refer to *Figure 6. Battery Compartment* for reference.

NOTE: Use care when storing and check the security of the set screws on fin hubs, line attachment and battery compartment **before each use.**



Figure 6. Battery Compartment

2.2.4 Power Supplies

Flight Modules

The flight modules are powered by eight AAA cells. Any type of cell³ may be used, though lithium AAA cells will offer the longest lifetime and lightest weight. Maximum current draw is approximately 103 mA. At sampling periods of once every 13 seconds or longer, the modules power down their 3-volt power supply for a significant fraction of the delay period (approximately 80% of the total delay) to greatly conserve power (reducing draw to approximately 14 mA).

The battery holder is located inside the battery compartment. The black end caps are slip fit into place for easy accessibility to the batteries. No special tools are necessary to access the batteries; just simply pull the end cap to remove and push to get back into place. There is room inside the caps for the wires and connector to sit.

Ground Station

The ground station is powered by 7-42 VDC. The power jack cord has an auto power plug, which fits the standard power ports in most vehicles giving you a ready 12V power supply in mobile applications.

NOTE: If you do not wish to use the 12V socket in your vehicle, a wide variety of options are available. AC to DC car charger sockets are available at many retailers. These will allow you to adapt the auto power plug so it will fit in a standard 120V AC home/business outlet.

3 Lithium, alkaline or rechargeable

2.3 *During Flight Operations*

2.3.1 *Operating Precautions*

The following is a list that users need to be aware of during flight operations to minimize unnecessary issues:

- Whenever using a module for the first time, or using it for the first time at a new geographic location, the compass should be calibrated.
- Calibrate the compass(es) before activating the ground station.
- Make sure that all antennas on the flight modules and the ground station are oriented horizontally to ensure the maximum transmission range as well as ensuring that a null is not created, which could potentially interrupt data transmissions to the ground station.
- Flight modules need to keep a distance of at least two feet apart from each other and ground stations when turned on and communicating.
- NEVER attach power to ground station without the antenna properly connected.



2.3.2 *System Setup & Flight Instructions*

These are the step-by-step instructions that need to be followed during flight operations. It will take you through the flight module and ground station setup and sequence. The following sections will go into more detail of the different operations.

- (1) Make sure the flight modules are fully assembled, equipped with battery supply and the antennas are attached in correct position; which is horizontal to the ground and in line with the boom pointing backwards. Modules should be in the off “0” position.
- (2) If the compasses need to be calibrated in the flight modules then do so according to *Section 2.3.4 Compass Calibration*.
- (3) Verify the antenna on the ground station is properly and securely attached to its jack. Make sure the antenna is oriented in a horizontal position so that the ground station will have maximum receiving capability.
- (4) Connect the computer to the Ground Station using a 9 pin RS-232 serial data cable.
- (5) Plug in and secure the DC auto power plug. Connect and secure the power jack to the ground station. Make sure the antenna is properly connected before attaching to power.
- (6) Turn on the ground station through the toggle power switch.
- (7) Follow the instructions indicated in *Section 2.3.9 Flight Software Sequence* for the PC guideline procedures during the flight operation.
- (8) Turn on the modules using the toggle switch accessible at the bottom of the housing unit by flipping it to the “1” position. It is good practice to activate the modules one at a time, only activating the next module when the previous module has successfully joined the network.

- (9) Verify power and transmission by the LEDs which are also located on the bottom of the housing unit. Learn more in *Section 2.3.5*.
- (10) Attach the module to the tether according to *Section 2.3.6*.

The ground station is designed to receive the flight module data and send it to your computer, where it is processed by the software. Computer to SmartTether™ Ground Station communication is accomplished through a 9 pin RS-232 serial data cable. Power is delivered to the Ground Station through the supplied power jack. There are three LED indicators on the ground station.

Transmit	
Receive	
Power	

2.3.3 Basic Startup

Turn the module on by pushing the toggle switch from “0” to “1”. The red LED “B” will be off, and the red LED “C” will be on. These two red LEDs monitor activity on the direct serial port and the radio modem, respectively. Blinking of these red LEDs indicates communication activity.

When the module is first turned on, there is a power-up sequence that happens at the very beginning. This feature is provided for specific calibration and reset functions. At first, the green LED “A” will blink rapidly for five seconds; which is the part of the power-up sequence mode. After this initial blinking, the unit will initialize itself and attempt to join the SmartTether™ network and run in normal mode.

IMPORTANT: When the green LED is blinking rapidly (several times per second) or slowly (twice per second), do NOT turn the power off unless you wish to enter either the calibration mode in Section 2.3.4 or reset mode in Section 3.3.2.

2.3.4 Compass Calibration

To enter the compass calibration mode, turn the module off during the power-up sequence mode, when the green LED “A” is rapidly blinking during the first five seconds after power-up. Then, turn the unit back on. The green LED will blink slowly for five seconds to indicate it has entered the compass calibration mode – do NOT turn it off during this time unless you wish to enter the communications reset mode! After blinking slowly for five seconds, the green LED will stay on for 20 seconds. During this time, slowly rotate the module twice in a complete circle, holding it level. This will complete the compass calibration procedure.

At the conclusion of the compass calibration procedure, the unit will again offer the user the choice of re-entering this mode by rapidly blinking the green LED for five seconds. If the module is allowed to proceed past this point, it will initialize and attempt to join the SmartTether™ network.

2.3.5 LED Indicators during Operation

During operation, the red LED “B” will ordinarily be off, and the red LED “C” will ordinarily be on. These LEDs will blink briefly during data transmissions. The green LED “A” indicates the status of the device when in the timing loops; it will blink while running, and be on while measurements are being taken. The two sampling periods which do not conform to this rule are the fastest speed (once per second) and also slowest speed (once every four seconds); the green LED “A” will be on continuously when using these rates due to internal logic. However, the red LEDs “B” and “C” will indicate the activity of the module.

2.3.6 Attaching Modules to the Line

SmartTether™ flight modules can be attached at any position along the tether line. If attached correctly, then the module can pivot and rotate freely in the direction of the wind while being strongly secured. The following steps will show how a module can be properly attached to the tether line.

- (1) Perform an inspection of the tether line and pivot line mount. The line should be checked for fraying or any other potential weak points.
- (2) Make sure the line attachment component is fully assembled according to the assembly directions in *Section 2.2.3*.
- (3) Pick a location on the tether line you would like the flight module to be attached.

NOTE: Anasphere’s winch system products have a line counter feature that measures the line’s distance.

- (4) Begin by taking one of the plastic snap–grip tube clamps and placing it around the tether line and the aluminum tube just underneath the rubber end cap. Tighten by pushing together the interlocking teeth with your fingers, about three or four “clicks”. To remove, use fingers to push teeth ends sideways in opposite directions and this will separate the teeth.
- (5) Keep the line tight and wrap the tether line around the upper aluminum tube clockwise for about five or six complete turns.
- (6) Keeping the line tight, wrap the tether line into the sideways “L” shaped slot on the front face of the aluminum rectangle block. Wrap the line around to the side of the main block and into the sideways “L” shaped slot on the back face of the block.
- (7) Keeping the line tight, wrap the tether line around the bottom aluminum tube counterclockwise for about five or six complete turns.

- (8) End by taking the second plastic snap-grip tube clamp and placing it around both the tether line and the aluminum tube just above the rubber end cap. Tighten by pushing together the interlocking teeth with your fingers, about three or four “clicks”. To remove, use fingers to push teeth ends sideways in opposite directions and this will separate the teeth.
- (9) Refer to *Figure 7. Line Attachment Diagram* for a visual reference of proper line mounting.
- (10) Let the SmartTether™ unit hang free on the tether and check to make sure that the shaft is balanced on the line according to *Section 2.3.7*.

NOTE: Make sure there are no sharp edges or ends do not come into contact with the tether line.

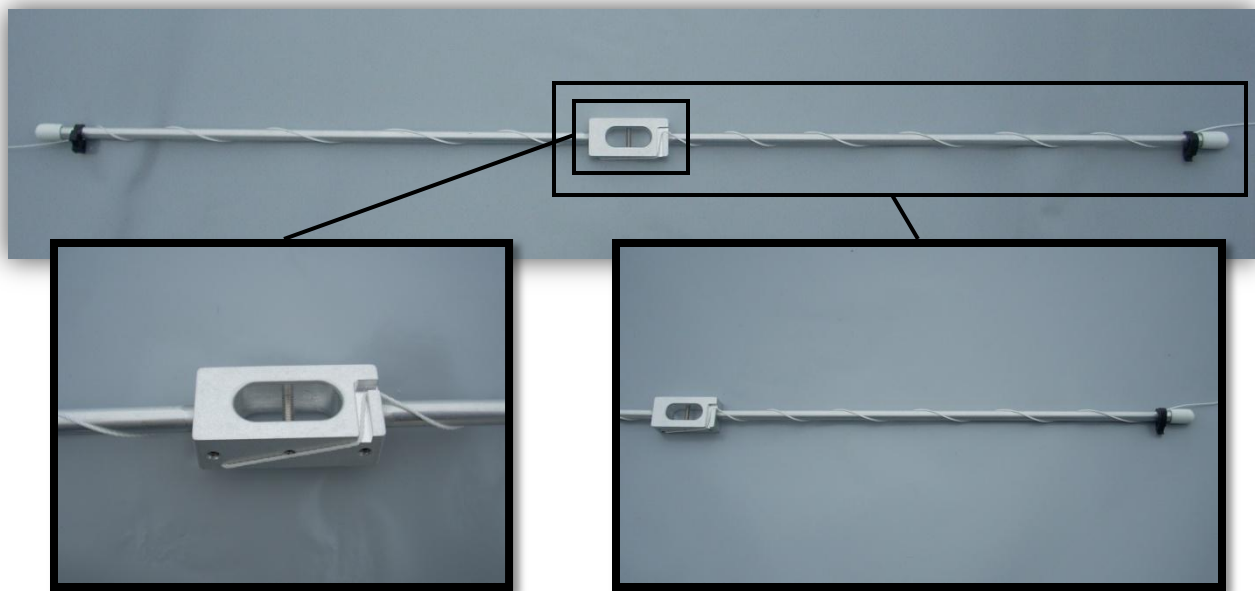

Figure 7. Line Attachment Diagram

2.3.7 Balancing

Balancing is critical for correct operation. When the module is secured to the tether line make sure that the boom balances level. This should only be done when the batteries are in place. If the module is titling more weight in one direction, then there are two options available for adjustments. Imbalance may occur when there is a weight difference with the supplied batteries.

The first and easiest way for a small adjustment is to slide the battery compartment forward or back on the boom. This can be done by loosening the three set screws on the plastic piece attached to the battery compartment, sliding it into a better position and then retightening the set screws. It should be noted that the housing will only move as far as the electrical wires allow it. There is about 1 ½” inch of total play with the battery compartment. In most cases, this adjustment is enough to correct the problem.

If necessary, another adjustment can be done by sliding the housing forward or back on the boom. With enough force the housing should be able to slide. Otherwise, in order to access this

adjustment, the user needs to open the housing by removing the two screws holding it closed. Inside the housing at both ends of the housing are click-snap tube clamps. A flat-bladed screwdriver can be used to loosen the clamps which anchor the housing in place onto the boom. Once loosened the entire housing unit can be moved up or down the boom to acquire the correct balance. Care should be taken to not jerk or put tension on any of the electrical wires while sliding the housing for balancing purposes. When the correct location is achieved, simply tighten the clamps again with your fingers to secure in place.

Once balancing is achieved and the module is properly attached to the tether line, it is ready to send up to take measurements.

Repeat the balancing steps for every SmartTether™ module.

2.3.8 Markers

User should tie the appropriate markers along the tether line. A marker can be made using a 12-ft long piece of 2-inch wide surveyor's marking tape tied around the line to yield two co-located 6-ft long streamers.

NOTE: In most regions of U.S. airspace, flights over 150 feet require markers to be placed every 50 feet on the line, with an area of at least 2 square feet. Check the FAA regulations for the appropriate marking requirements, notice requirements, and altitude limitations for the airspace you will be operating in.

2.3.9 Flight Software Sequence

- (1) Open the SmartTether™ program.
- (2) Make sure the base station is connected to an available serial port on your computer and turn it on. This may require a special adapter cable, especially if using a laptop, as most newer models do not have a serial port. A USB to serial adapter cable is generally available at most local electronics stores.
- (3) Click the **“Find Base Station”** button at the top left of the screen. Select the correct serial port from the list presented and click **“OK”**.
- (4) Click **“OK”** after the base station has been configured. If configuration fails, make sure the base station is powered up and connected to the correct serial port and try again. Occasionally, cycling power on the base station may be necessary before it will configure.
- (5) Click on the **“Acquire Stations”** button.
- (6) Turn the power on using the toggle switch for the first SmartTether™ weather station module to be used. Wait for the program to acquire the first station. This step typically takes 20-30 seconds.

- (7) Enter the (integer) altitude above ground level at which you will fly this unit. You may use any units you desire. This number will be logged in the data file, and used to graph the data vs. altitude in real time.
- (8) This station is now ready to be raised on the tether. If you choose to acquire all nodes before attaching to the tether, be certain to attach them in the same order as they were acquired. The first station acquired should be the highest on the tether.
- (9) After the first station is acquired, turn the second station on and repeat this process until all of the stations to be used have been acquired.
 - Acquire each individual station one at a time.
 - Never allow antennas from two running units to be within 18 inches of each other.
- (10) When all of the stations have been acquired, click **“OK”**.
- (11) Click on the **“Run”** button to start running the program and collect real time data. When prompted, enter a name for the saved data file. This file will be tab-delimited text, appropriate for importing into Excel, Open Office, or another spreadsheet program for analysis.
 - You will be prompted here to give the project a file name.
- (12) The system will begin collecting and displaying data once per second. Use the **“Set Interval”** button at the upper right to change the data collection interval.
 - Note that the tether can enter a power-saving mode between data intervals. Any change to the interval will not take effect until the next data is received. The number of seconds until data is expected next is reported near the upper right corner.
- (13) Click the **“Data”** tab to see the most recent data each sensor has collected.
 - Station ID is unique to each unit, but can be overridden with the SmartTether™ calibration program.
 - Altitude is the number the user entered during acquisition.
 - Pressure is reported in mbar.
 - Temperature is reported in degrees Celsius.
 - Humidity is reported in % RH.
 - Wind direction is reported in degrees.
 - Wind speed is reported in m/s.
- (14) Click on the **“Graph”** tab to see a plot of the most recent data. To customize the graph, click over any part of the graph area.
 - A menu will pop up allowing for a tailored set-up for the graph of both the dependent and independent axis.
 - An independent variable of either altitude or pressure may be chosen and a range set.
 - Altitudes are the numbers entered during station acquisition.
 - Pressures are measured values. The pressure plot is logarithmic.

- Ranges can be chosen for each sensor type on the dependent axes.
 - Grid lines on the dependent axes are determined by the interval chosen for the temperature axis.
- (15) Click the “**Stop**” button to stop the data acquisition. Data acquisition will stop after the next data set is received. Until that time, pressing “Run” will cancel the “Stop” action, and continue appending data to the current file. After data acquisition stops, pressing “Run” will require a new data file be specified.
- (16) After the program is closed manually, restarting will require switching each SmartTether™ station off before they can be reacquired. A confirmation message is displayed whenever the user attempts to quit the program.
- (17) In the event that the host computer crashes, the SmartTether™ program will have a record of the current network state. Upon restarting, the user is walked through an attempt to reacquire the network without having to restart the units. In most cases, data collection can continue without having to lower the blimp.

3 Technical Specifications

3.1 Ground Station

Digital Output: RS232, 9 Pin, bi-directional

Ground Station Power Supply: 7-42 VDC, unregulated, at 500 mA.

3.2 Flight Modules

Flight Module Power Supply: 8 AAA cells

- Lithium Batteries such as Energizer L91 Ultimate Lithium are recommended
- Alkaline and rechargeable cells are also acceptable but will have shorter lifetimes.

Operating Lifetime at 1 Hz: With 8x AAA lithium cells: approx. 11.6 hours
With 8x AAA alkaline cells: approx. 9.3 hours

-Lifetime may vary depending upon factors, including battery manufacturer and temperature.

-Lifetime may be extended up to 7 times by reducing sampling rates- rates of once every 13 seconds or slower have maximum power savings.

Sensors:

Pressure:	resolution 0.1 mb (tenths place not significant) accuracy 3 mb range 0-1035 mb
Precision Pressure Option:	resolution 0.1 mb (tenths place significant) accuracy .5 mb range 0-1100 mb
Temperature:	resolution 0.125C accuracy 0.5C range -55 to +125 °C
Relative Humidity:	resolution 0.1% accuracy 3% range 0-100%
Wind Speed:	resolution 0.1 m/s accuracy 1 m/s or 5%, whichever is greater range 0-59 m/s ⁴
Wind Direction:	resolution 1 degree accuracy 2 degrees
Extra Channels:	analog: 0-5 volt channels 12-bit analog-to-digital conversion digital: 5-volt CMOS logic level input

*Extra channels may be enabled on request in version 3.1. Please contact Anasphere for details.

Data Rate:

1 Hz maximum, adjustable in one second intervals

Module Mass:

No batteries:	624 grams
With 8x Alkaline AAA cells:	737 grams

3.3 Maintenance

In order to ensure the function and longevity of your SmartTether™ system some basic maintenance steps are required. When not in use, it is recommended that the system be stored in a cool, dry place. If desired external system components (i.e., the system fins, main housing,

4 WARNING: speeds over 11 m/s may be measured but exceed the demonstrated flight envelope of the modules and such flights are at the user's own risk.

shaft, and anemometer) may be wiped down with a damp cloth to remove external dirt and debris. Additionally, after using the SmartTether™ system it is recommended that the batteries be removed.

4 Troubleshooting

4.1 Harmful Interference

If this equipment does cause harmful interference to radio or television reception, which can be determined by turning the equipment off and on, the user is encouraged to try to correct the interference by one or more of the following measures:

- Reorient or relocate the receiving antenna.
- Increase the separation between the equipment and receiver.
- Connect the equipment into an outlet on a circuit different from that to which the receiver is connected.
- Consult the dealer or an experienced radio/TV technician for help.

4.2 Communications Reset

It is possible, through the advanced configuration features of the SmartTether™ modules, for a user to corrupt the communication settings of the module. If a module is not communicating and a corrupted configuration is suspected, the user can reset the communications parameters as follows.

Enter the compass calibration mode as in *Section 2.3.4*, but when the green LED is blinking slowly, turn the module off. Then, turning the module on again will reset the communications modes to their default values. Following that, the module will proceed to again offer the user the option of entering the compass calibration mode, and from there proceed to initialize and attempt to join the SmartTether™ network.

5 Technical Support

Technical support is available to help you troubleshoot any potential problems or answer any technical questions you may have about your SmartTether™ system. Live support is available Monday through Friday 9am to 5pm MST, excluding federal holidays, at 406-994-9354. Also e-mail inquiries are accepted at the following address info@anasphere.com.

6 Additional Information

6.1 Serial Communications

There are two communications ports used by each module. One is a direct, hard-wired link, and the other is the RF link.

6.1.1 Direct Serial Link

This link is available through the 3-pin connector (J2) along the side of the module. An adapter cable which connects this port to a standard 9-pin RS-232 connector is included with the SmartTether™ system. This port serves two purposes: calibration and separate monitoring of data output from the module. Port settings are 9600 baud, 8 data bits, no parity, 1 stop bit. Output signal levels used on this port are 0 VDC and 5 VDC; the vast majority of current serial ports will accept these signals without any problem. Input signal levels can be tolerated up to standard RS-232 levels. This port is monitored with the upper red LED.

6.1.2 Radio Modem Link

This link is only on the board, and is directly between the microcontroller and the radio modem. This port is monitored with the lower red LED.

6.2 Extra Channels

The SmartTether modules offer extra analog (input) and digital (input or output) channels which can be used for adding additional user-supplied sensors or devices. The number of extra channels available depends on module configuration. These channels are sampled (if an input) or controlled (if an output) once every measurement cycle. The default module configuration has these extra channels disabled.

Connections to the extra channels are made through the J1 port along the side of the circuit board. Power (+5 VDC, maximum recommended current draw 300 mA for user-supplied items) and ground are available at each extra channel connection point. Extra channels may thus be connected using 0.1-inch pitch 3-pin connectors. SmartTether version 3.1 and 3.2 modules use some of these channel locations for sensors and other features. Contact us if you wish to implement any extra channels.

6.3 Notices

This equipment has been tested and found to comply with the limits for a Class B digital device, pursuant to part 15 of the FCC Rules. These limits are designed to provide reasonable protection against harmful interference in a residential installation. This equipment generates, uses and can radiate radio frequency energy and, if not installed and used in accordance with the instructions, may cause harmful interference to radio communications. However, there is no guarantee that interference will not occur in a particular installation. If this equipment does cause harmful interference to radio or television reception then refer to *Troubleshooting (p. xx)* for the appropriate measures.

FCC Compliance

Contains FCC ID: MCQ-XBEEEXSC

The enclosed device complies with Part 15 of the FCC Rules. Operation is subject to the following two conditions: (i.) this device may not cause harmful interference and (ii.) this device must accept any interference received, including interference that may cause undesired operation.

RF Exposure

WARNING: This equipment is approved only for mobile and base station transmitting devices. Antenna(s) used for this transmitter must be installed to provide a separation distance of at least 20 cm from all persons and must not be co-located or operating in conjunction with any other antenna or transmitter.

FCC approved Antennas

WARNING: This device has been tested with Reverse Polarity SMA connectors. Antennas must be tested to comply with FCC Section 15.203 (unique antenna connectors) and Section 15.247 (emissions).

6.4 Liability

Responsibility for the consequences of using the hardware/software and for the intended or achieved results of its use rests solely with the purchaser.

In no event shall Anasphere, Inc. or any person involved in the creation, production, or distribution of this Anasphere, Inc. product be liable for any claim of damages, including but not limited to any damages assessed against or paid by you to any third party, arising from the use, quality or performance of such Anasphere, Inc. product including hardware, software, firmware, or documentation, even if Anasphere, Inc. or any such person has been advised of the possibility of damages for any claim by any other party. Some states do not allow the limitation or exclusion of liability for incidental or consequential damages, so the above limitations may not apply.

The purchaser understands and agrees that Anasphere, Inc. is not responsible or liable for damage to equipment caused by the use of its products.

Purchaser understands that it uses Anasphere, Inc. products at its own risk and agrees to indemnify, defend, and hold harmless Anasphere, Inc. from any and all claims arising from the use of its products.

6.5 Warranty

Anasphere, Inc. warrants this product to be free from defects in materials and workmanship for a period of **6 months** from the date of shipment. During the warranty period, Anasphere, Inc. will, at its option, either repair or replace products that prove to be defective.

This warranty shall not apply to any defect, failure or damage caused by misuse, abuse, improper application, alteration, accident, disaster, negligence, use outside of the environmental specifications, improper or inadequate maintenance, normal wear, or incorrect repair or servicing not performed or authorized by Anasphere, Inc.